



## Goedhart VCI

Industrial air coolers for cooling & freezing applications

Cu/Al

R404A - CO<sub>2</sub>



# Goedhart VCI

The extensive range Goedhart VCI single discharge ceiling mounted industrial air coolers are available with capacities between 2,8 and 264,4 kW. The Goedhart VCI air coolers are suitable for cooling and freezing applications and with a wide variety of accessories and options available. The coil block is standard build from aluminium end plates, copper tubes and aluminium fins. The fans are arranged for blow-through air configuration for the Goedhart VCI-B and draw-through for the Goedhart VCI-Z (please state which is required when ordering).. The modular design incorporates 5 different sizes of fan, with model options of up to 8 fans per cooler.

## Type description

### Goedhart VCI-B 62567

B=blow through  
Z=draw through

Number of rows deep  
Number of fans  
Fan diameter [cm]  
Fins spacing [mm]

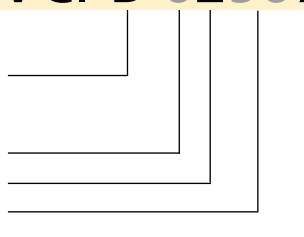

## Coil block

- Tube pitch : 50x50 mm straight
- Fin spacing : 4, 6, 7, 8, 10 and 12 mm
- Material : 15mm o.d copper tube
- : aluminium HT-lamellen
- Optimized cooling circuits
- Standard refrigerant connections are positioned on the left hand side of the unit when looking with the direction of the airflow.
- A good thermal contact is achieved by expansion of the tubes into the fin collars, that are also utilised as spacers to provide a constant distance between the fins.
- All coolers are pressure tested to 30 bar (lower by cooling mediums) and are supplied with a light over pressure charge of dry nitrogen.
- Suitable for all known refrigerants and coolants, with the exception of NH3.

## Casing

- Construction for ceiling mounting
- The flush mounting protects against and prevents accumulation of dust and dirt.
- Casing material of galvanized sheet steel
- Finishing is standard white epoxy spray (RAL 9003)
- Bend/header projection by end covers, easy removed for maintenance
- Defrost by hot gas spiral or electric defrost elements will be fixed to the bottom side of the coil.
- Stainless steel fasteners

# General range features

## Capacity

The listed nominal cooling capacities are based on R404A, DT1, RH of 85% and 4 pole 3 phase fans connected in  $\Delta$ .

### Influence of Coating on Capacity

The use of coated fins, or of a fully coated coil will result in a capacity decrease of approximately 3%

### Capacity optimisation

Since Goedhart tries to limit stock products, we are capable of optimising the circuitry of our evaporators. In order to do this, the following information is needed :

- Design capacity
- Air volume
- Refrigerant
- Air on temperature
- Evaporating temperature
- Liquid temperature before expansion valve.

## Sound data

The mean sound pressure (LpA @ 3m  $\pm$  2 dB (A)) each air cooler is a calculated indication value according to the EN13487 standard parallel pipe. Goedhart uses the fan manufacturer's sound power level (LwA) at the inlet side of the fan. Changes to or by the fan or the product, affect the sound, in these cases, consult the manufacturer for the new indication value. In critical sound requirements, we advise you to consult an expert.

## Defrostsystem:

For room temperatures where ice build-up can be expected and where the coilblock can not be defrosted by the room air, electric or hotgas defrost is necessary.

With low temperatures we also advise fan periphery heating.

### Electrical defrost:

The Goedhart VRB and VRZ can be provided with electric defrost. A distinction can be made here between heavy defrost loads for low temperatures and light defrost load for higher temperatures (room temperature approximately 0 °C). The stainless steel heater elements are fitted in the coilblock in tubes, which forms a high conductive medium between the heaters and the fins. The driptray heaters are fitted to the underside of the aluminium inner tray with aluminium profiles. The heater elements which are rated for 220/240 V are connected for supply 380/415 V with neutral. The coilblock elements are removable from the end opposite to the refrigerant connections, whilst the tray heater elements can

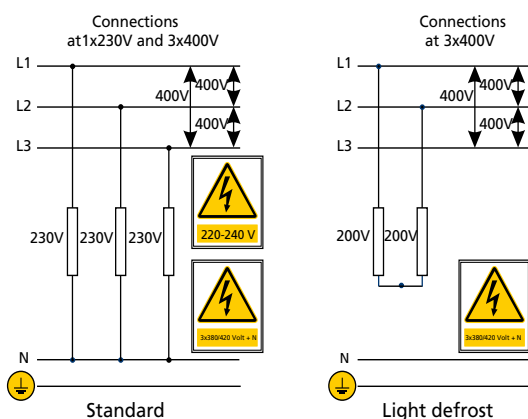

be removed once the outer tray has been taken off.

### Hot gas defrost:

The coil block is suited for hot gas defrost (hot gas supply through the suction header). At an extra price the driptray can be provided with a hotgas/cooling medium spiral. The stainless steel tubes of the hotgas spiral are enclosed in special aluminium profiles that are rigidly secured to the underside of the aluminium inner tray, thus providing a good bond for maximum heat transfer. Just as with electric defrost a distinction is made with hotgas defrost between light defrost load (room temperature about 0°C) and heavy defrost load.

## Accessories:

Standard accessories for the Goedhart VCI air coolers are:

- blow-through / draw-through air configuration
- Electric defrost, hot gas defrost and/or water defrost
- Fan periphery heating
- Hinged drip tray.
- Insulated drip tray
- Insulated hygienic polyester drip tray
- Goedhart VCI-Z supplied with bellmouth connection per fan for a longer air throw
- Goedhart VCI-B supplied with air diffusor for a longer air throw
- Goedhart VCI-B supplied with air diffusor with air operated damper to increase defrost efficiency (airvolume reduced to approx. 90% and capacity reduced to approx. 95%)

The accessories are included in the price list.

## Optional extras:

Various optional extras for the VCI are available, price and delivery upon request:

- Isulation disks
- Feet for floor mounting
- Coating of the coil block
- Fan hood
- Hinged fan plates
- 60 Hz motors
- EC-fans
- Single phase motors
- Coolants (glycol, water, etc.)
- Pump system
- Other casing materials
- Other fin spacings
- Sea water resistant fins

## Mounting and Maintenance

Goedhart VCI is delivered on a wooden frame. When on the frame, Goedhart VCI can be handled by forklift truck, which makes positioning and installation simple. Refer to our maintenance and installation manual.



# Fans

Because of the flexible construction of the Goedhart VCI air cooler, in principle it is possible to deliver with different fans. GEA Goedhart selected a standard fan range of Ziehl Abegg (we reserve the right to alter the manufacturer) which fit perfectly on the Goedhart VCI air coolers. The fans can be supplied in both blow-through and draw-through executions. Against an extra price and with extra delivery times stainless steel guards and EC-fans are available.

## Execution

The fans meet the ErP directive. The fans have very good aerodynamic features because of the special impeller geometry. This special impeller geometry gives the fan a low noise level and an high efficiency.

1x230V fans are suitable for a room temperature till -25°C. 3x400V fans are suitable for a room temperature till -40°C. When lower room temperatures are desired, special fans are need.

- Tension : 3x400V-50Hz-3 phase  
: 1x230V-50Hz-1 phase  
(60Hz execution on request)
- Protection class : IP44 / IP54
- Color : RAL9005 (black)
- Speed controlling : - 3 Phase motors are suitable for 2-speed regulation by  $\Delta$ -Y reconnection.  
- 3 Phase motors are suitable for frequency controller with all-pole sinus filter.  
- 1 Phase motors are suitable for phase control and transformer.

The motors are standard executed with a thermo contact (TB) and must be connected to prevent motor damages. The maximum allowable working data in the table and on the name plate of the fans are to operate in an air temperature of 20 °C (air density of  $\rho = 1,2 \text{ kg/m}^3$ ). For air temperatures lower then +20 °C, the current amperage can be calculated by using the diagram multiplication factor, suitable thermal overloads can then be selected.

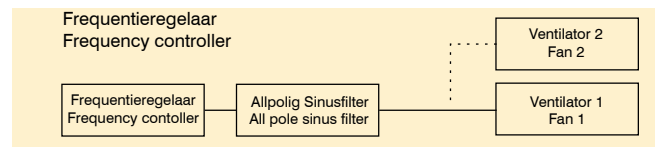
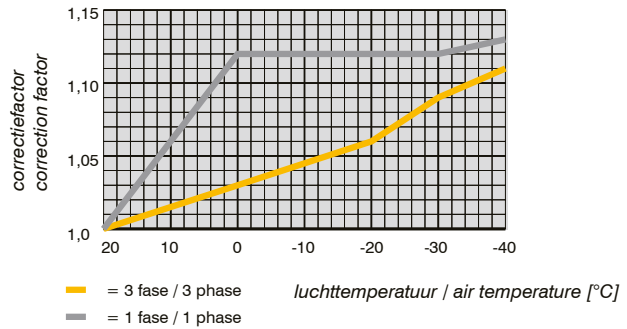

## Three phase - 50 Hz

Fan type	Tension V	$\Delta$				Y				Wiring diagram blow-through/ draw-through
		Speed min <sup>-1</sup>	Input Watt	FLC A	Sound power indication each fan LwA (+/-2dB(A)) dB(A)	Speed min <sup>-1</sup>	Input Watt	FLC A	Sound power indication each fan LwA (+/-2dB(A)) dB(A)	
<b>4 pole (n=1500 min<sup>-1</sup> nom.)</b>										
FN040	3x400/690	1370	230	0.44	76	1110	170	0.27	70,5	108B/108A
FN045	3x400/690	1250	350	0.64	78	950	220	0.35	70	108B/108A
FN050	3x400/690	1330	830	1.45	81	940	550	0.97	75	108B/108A
FN056	3x400/690	1280	1050	2.20	85	920	580	1.10	76	108B/108A
FE063	3x400/690	1330	1450	2.60	89	1080	980	1.60	84	108B/108A
<b>6 pole (n=1000 min<sup>-1</sup> nom.)</b>										
FN045	3x400/690	860	180	0.39	67	640	100	0.19	61	108B/108A
FN050	3x400/690	870	290	0.74	72	590	150	0.36	64	108B/108A
FN056	3x400/690	870	340	0.70	73	630	210	0.38	65	108B/108A
FN063	3x400/690	900	630	1.25	74	720	440	0.73	69	108B/108A

## Single phase - 50 Hz

Fan type	Speed min <sup>-1</sup>	Input Watt	FLC A	Sound power indication each fan LwA (+/-2dB(A)) dB(A)	Wiring diagram blow-through/ draw-through
<b>4 pole (n=1500 min<sup>-1</sup> nom.)</b>					
FN040	1350	240	1.10	76	104B/104A
FN045	1290	390	1.75	80	104B/104A
FN050	1230	750	3.35	81,5	104B/104A
<b>6 pole (n=1000 min<sup>-1</sup> nom.)</b>					
FN040	950	130	0.58	68	104B/104A
FN045	860	180	0.82	68,5	104B/104A
FN050	910	300	1.30	71,5	104B/104A

## Wiring diagram fans for blow-through air coolers

### Ziehl Abegg 1x230V-50Hz (104XB)

U1 = bruin  
 U2 = blauw  
 Z1 = zwart  
 Z2 = oranje  
 TB = wit

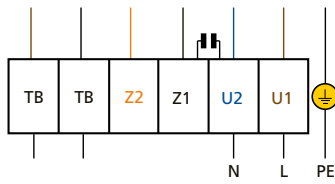

## Wiring diagram fans for draw-through air coolers

### Ziehl Abegg 1x230V-50Hz (104XA)

U1 = bruin  
 U2 = blauw  
 Z1 = zwart  
 Z2 = oranje  
 TB = wit

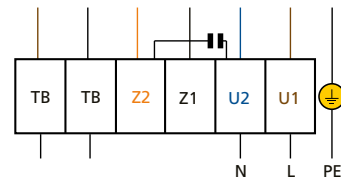

### Ziehl Abegg 3x400V (Δ)-50Hz (108XB)

U1 = bruin  
 V1 = blauw  
 W1 = zwart  
 U2 = rood  
 V2 = grijs  
 W2 = oranje  
 TB = wit

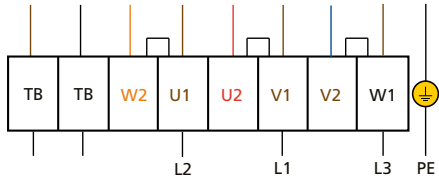

### Ziehl Abegg 3x400V (Δ)-50Hz (108XA)

U1 = bruin  
 V1 = blauw  
 W1 = zwart  
 U2 = rood  
 V2 = grijs  
 W2 = oranje  
 TB = wit

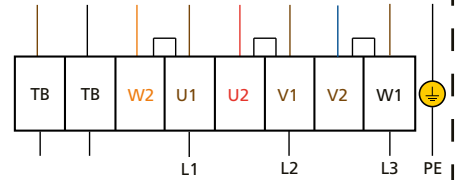

### Ziehl Abegg 3x400V (Y)-50Hz (108XB)

U1 = bruin  
 V1 = blauw  
 W1 = zwart  
 U2 = rood  
 V2 = grijs  
 W2 = oranje  
 TB = wit

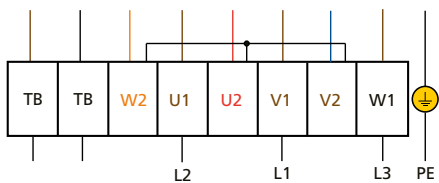

### Ziehl Abegg 3x400V (Y)-50Hz (108XA)

U1 = bruin  
 V1 = blauw  
 W1 = zwart  
 U2 = rood  
 V2 = grijs  
 W2 = oranje  
 TB = wit

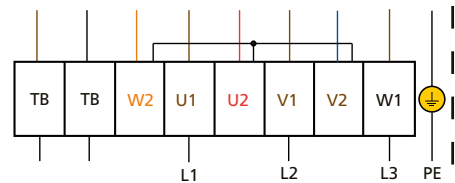

## Fan heating

To prevent the freezing of the impeller of the fan during the defrost cyclus of the air cooler, a fan heater can be used.

Fan diameter	Diameter element	Power (230V)
mm	D in mm	kW
400	435	0,50
450	485	0,63
500	535	0,63
560	595	0,76
630	665	0,89

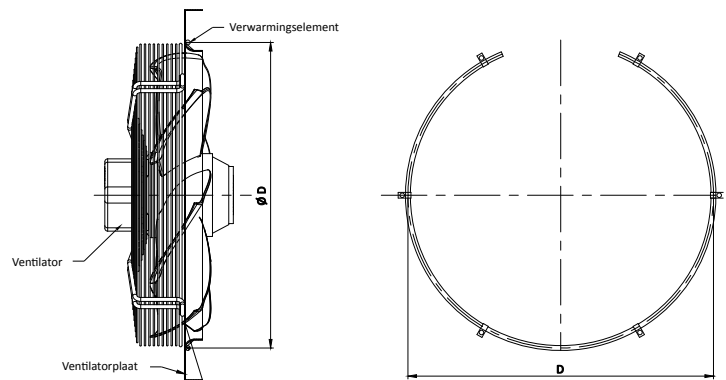

# Correction factors

## Correction factors DT1 (=air-on)

The capacities are based on R-404A direct expansion, DT1 and a RH of 85 %. DT1 is the difference between air-on temperature and the evaporation temperature of the cooler. The evaporation temperature is the saturate temperature corresponding to the pressure at the suction outlet of the cooler.

The nominal capacities:

- (SC1)  $t_o=0^{\circ}\text{C}$  and  $\text{DT1}=10\text{K}$
- (SC2)  $t_o=-8^{\circ}\text{C}$  and  $\text{DT1}=8\text{K}$
- (SC3)  $t_o=-25^{\circ}\text{C}$  and  $\text{DT1}=7\text{K}$

Correction factors for various air-on temperatures and temperature differences (DT1) are as indicated in the table below. The requested capacity must be multiplied by a correction factor from the table, so that a cooler with the resulting nominal capacity can be chosen from the selection tables.

$Q_{\text{nominal}} = \text{factor} \times Q_{\text{requested}}$

### Cooling

DT1	SC1-DT1 =10K-Air-on=10°C (0/+10)									
	Evaporation temperature (°C)									
K	+7	+6	+5	+4	+3	+2	+1	0	-1	-2
6	1,87	1,87	1,87	1,88	1,88	1,89	1,89	1,89	1,89	1,90
7	1,53	1,53	1,54	1,54	1,54	1,55	1,55	1,55	1,55	1,56
8	1,28	1,28	1,28	1,29	1,29	1,30	1,30	1,30	1,30	1,31
9	1,11	1,11	1,11	1,12	1,12	1,13	1,13	1,13	1,13	1,14
10	0,98	0,98	0,98	0,99	0,99	0,99	1,00	1,00	1,00	1,01
11	0,89	0,89	0,89	0,90	0,90	0,91	0,91	0,91	0,91	0,92
12	0,78	0,79	0,79	0,79	0,80	0,80	0,80	0,80	0,80	0,81

### Cooling / Freezing

DT1	SC2-DT1 =8K-Air-on=0°C (-8/0)									
	Evaporation temperature (°C)									
K	-3	-4	-5	-6	-7	-8	-9	-10	-11	-12
6	1,32	1,34	1,39	1,43	1,46	1,46	1,47	1,47	1,48	1,49
7	1,05	1,08	1,12	1,15	1,18	1,19	1,19	1,20	1,20	1,21
8	0,86	0,88	0,91	0,94	0,97	1,00	1,00	1,01	1,01	1,02
9	0,76	0,76	0,78	0,80	0,82	0,86	0,86	0,87	0,87	0,88
10	0,66	0,67	0,69	0,71	0,73	0,74	0,74	0,75	0,75	0,76
11	0,58	0,59	0,59	0,60	0,62	0,64	0,64	0,65	0,66	0,67
12	0,55	0,54	0,54	0,54	0,55	0,55	0,56	0,57	0,58	0,59

### Freezing

DT1	SC3-DT1 =7K-Air-on=-18°C (-25/-18)									
	Evaporation temperature (°C)									
K	-21	-22	-23	-24	-25	-26	-27	-28	-29	-30
6	1,20	1,20	1,21	1,21	1,22	1,22	1,23	1,23	1,24	1,24
7	0,99	0,99	0,99	1,00	1,00	1,00	1,01	1,01	1,02	1,02
8	0,83	0,84	0,84	0,84	0,85	0,85	0,85	0,85	0,86	0,86
9	0,72	0,72	0,72	0,73	0,73	0,73	0,73	0,74	0,74	0,74
10	0,63	0,63	0,63	0,64	0,64	0,64	0,64	0,65	0,65	0,65
11	0,56	0,56	0,56	0,57	0,57	0,57	0,50	0,58	0,58	0,58
12	0,50	0,51	0,51	0,51	0,51	0,51	0,52	0,52	0,52	0,52

### Calculation example

Fin spacing	: 6 mm	-	DT1 = +3- (+10) = 7K
Required capacity	: 30 kW	-	Correction factor = 1,54
Air-on temperature	: +10 °C	-	Multiply required capacity with correction factor.
Refrigeration temp.	: +3 °C		30 kW x 1,54 = 46,2 kW
Condition	: SC1		
Refrigerant	: R-404A	-	Select air cooler from the table (SC1 type VCI-B 63506=47,5 kW)

## Attention!

### Moisture carry over from the coil block:

When you select VCI-B with a Ø500 mm fan in an application with a high relative humidity and/or defrost with room air, Goedhart advises the use of a fan with a low pitch angle or the draw-through execution VCI-Z. Thus, you will avoid the risk of moisture carry over from the coil block. The fan with a low pitch angle give a reducing of the capacity of approx. 5% and a reduction of the air volume of approx. 10%.

### Air throw\*\* (only draw-through execution)

The air throw mentioned in the selection table indicated with \*\* is based on an air temperature of 20°C, blowing under a flat ceiling without any obstruction. The height and air circulation fold of the room can influence the air throw. The air speed at the end of the throw-length is 0,25 m/sec



# Goedhart VCI Drawing

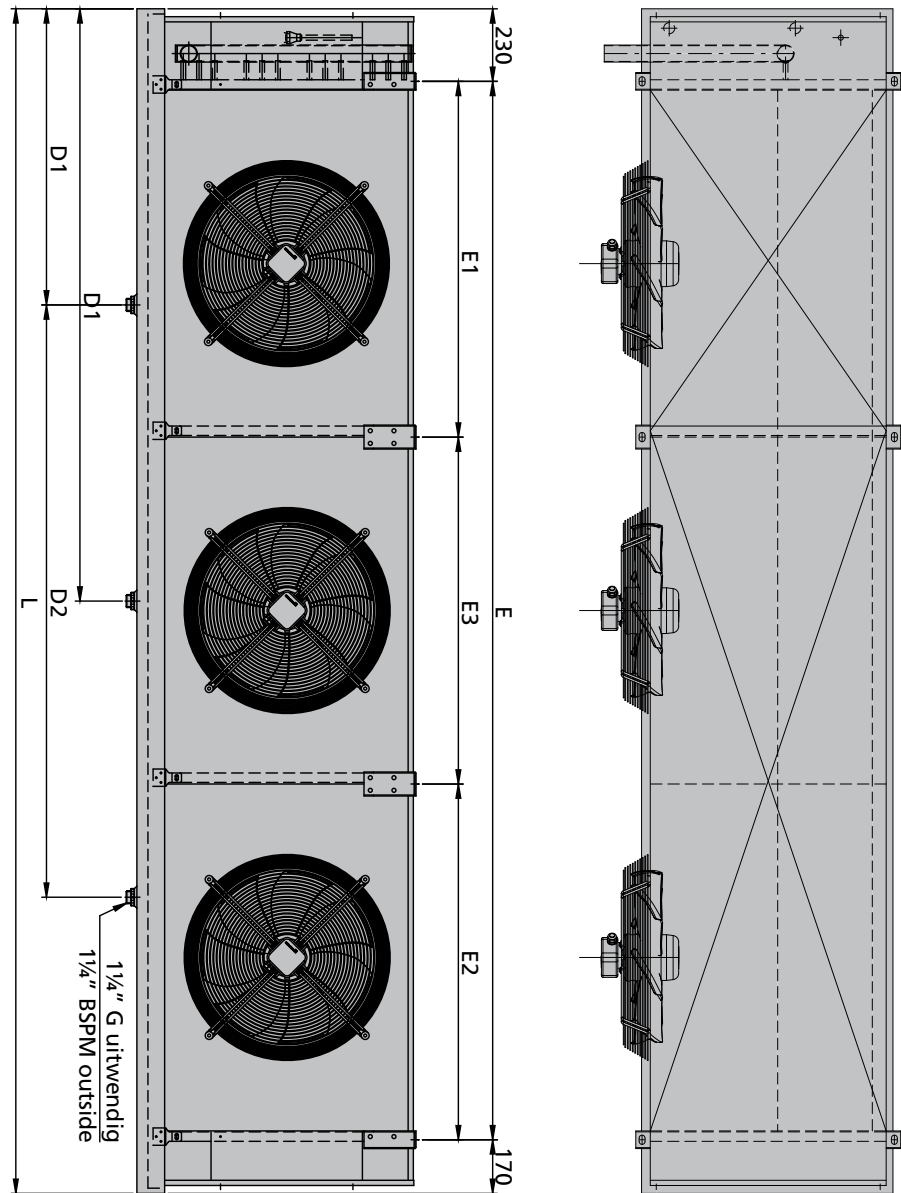
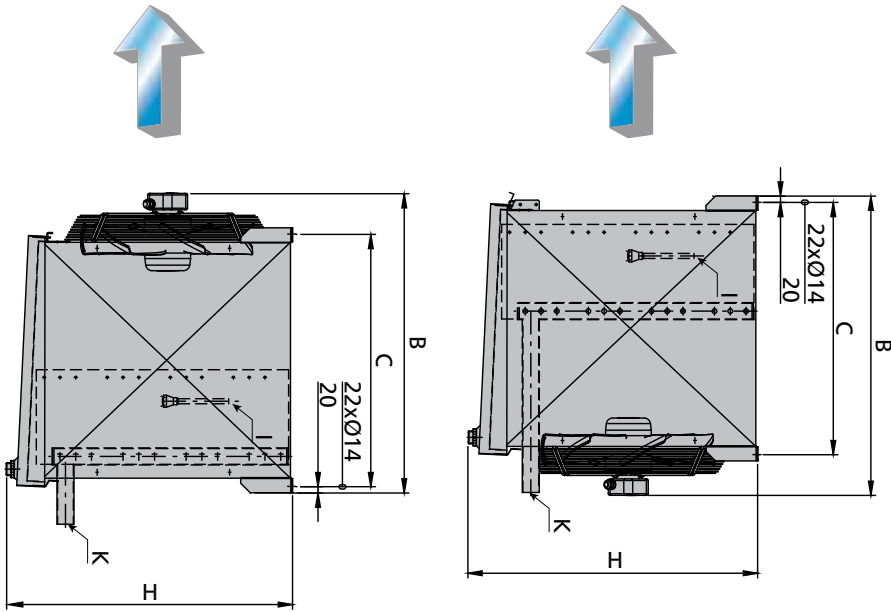







## Best of both worlds

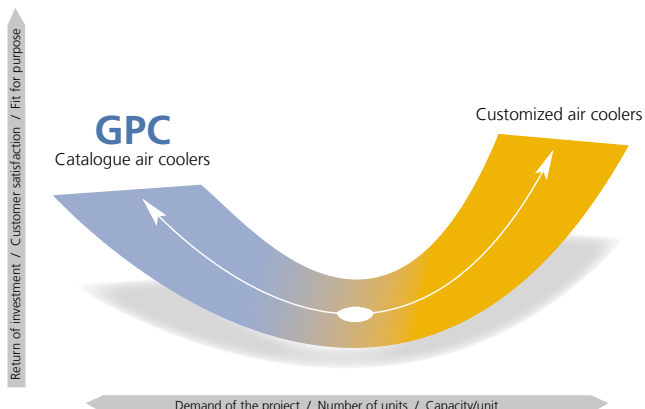

One question which always is in the mind of an industrial refrigeration engineer is the following:  
Do I ask for standard or shall I go for tailor made?

There are good reasons for both choices. In some cases, the solution needed is beyond the boundaries of the standard program. In other occasions, tailor made can even offer a more economical solution. In again other situations standard would be the logical choice to go for.

In any of the cases GEA Goedhart can offer you the right solution. With the standard selection software GPC finding the right heat exchanger is just a few mouse clicks away. On other cases the GEA Goedhart engineers are happy to help you out!

Goedhart GPC Program,  
**your selection software**  
for air coolers and air  
cooled condensers!

Goedhart VCI air cooler selections are available in the Goedhart Product Catalogue or GPC.

On the tool section of [www.goedhart.nl](http://www.goedhart.nl) you will find the download button for the latest version of the GPC.

The GPC program is an easy to use tool for contractors, consultants and every other thinkable user and gives you access to many advantages such as:

- Multilingual
- The whole range of GEA Goedhart standard air coolers and air cooled condensers
- Pre-select buttons to application
- Selections including drawings and an extensive list of accessories
- Spare parts
- Accurate capacities: Under the GPC shell hides a sophisticated capacity calculation program which optimizes circuits to the design conditions as you work!



For Contractors and Original Equipment Manufacturers (OEM) related to the industrial refrigeration industry, GEA Goedhart B.V. offers an unlimited range of air coolers and air cooled condensers in several configurations.

Depending on the application, the optimum configuration will be selected in close cooperation with our customers.

### Configurations

The following material combinations are available in various tube pitches and various fin spacing:

Tube material	Fin material
Copper (Cu)	Aluminium (Al)
Stainless steel (Stst)	Aluminium (Al)
Stainless steel (Stst)	Stainless steel (Stst)
Aluminium (Al)	Aluminium (Al)
Hot dipped galvanized steel (FeZn)	Hot dipped galvanized steel (FeZn)

### Options on aluminium fins

- Goldlack coated fins
- Seawater resistant aluminium fins (AlMg)

### Applications

Cooling	Freezing
Cold stores / Distribution centres	Cold stores / Distribution centres
Food processing rooms	Tunnel / spiral freezers
Fruit storage	Slaughter houses
Banana ripening storage	Automotive testing rooms
Greenhouse conditioning	Ski domes

### Pressure Equipment Directive (P.E.D.)

All aircoolers produced by Goedhart comply with the Pressure Equipment Directive 97/23/EC. PED certificates can be downloaded from [www.goedhart.nl](http://www.goedhart.nl).

## GEA Goedhart air coolers for every application



# Goedhart industrial air coolers

## Catalogue ranges

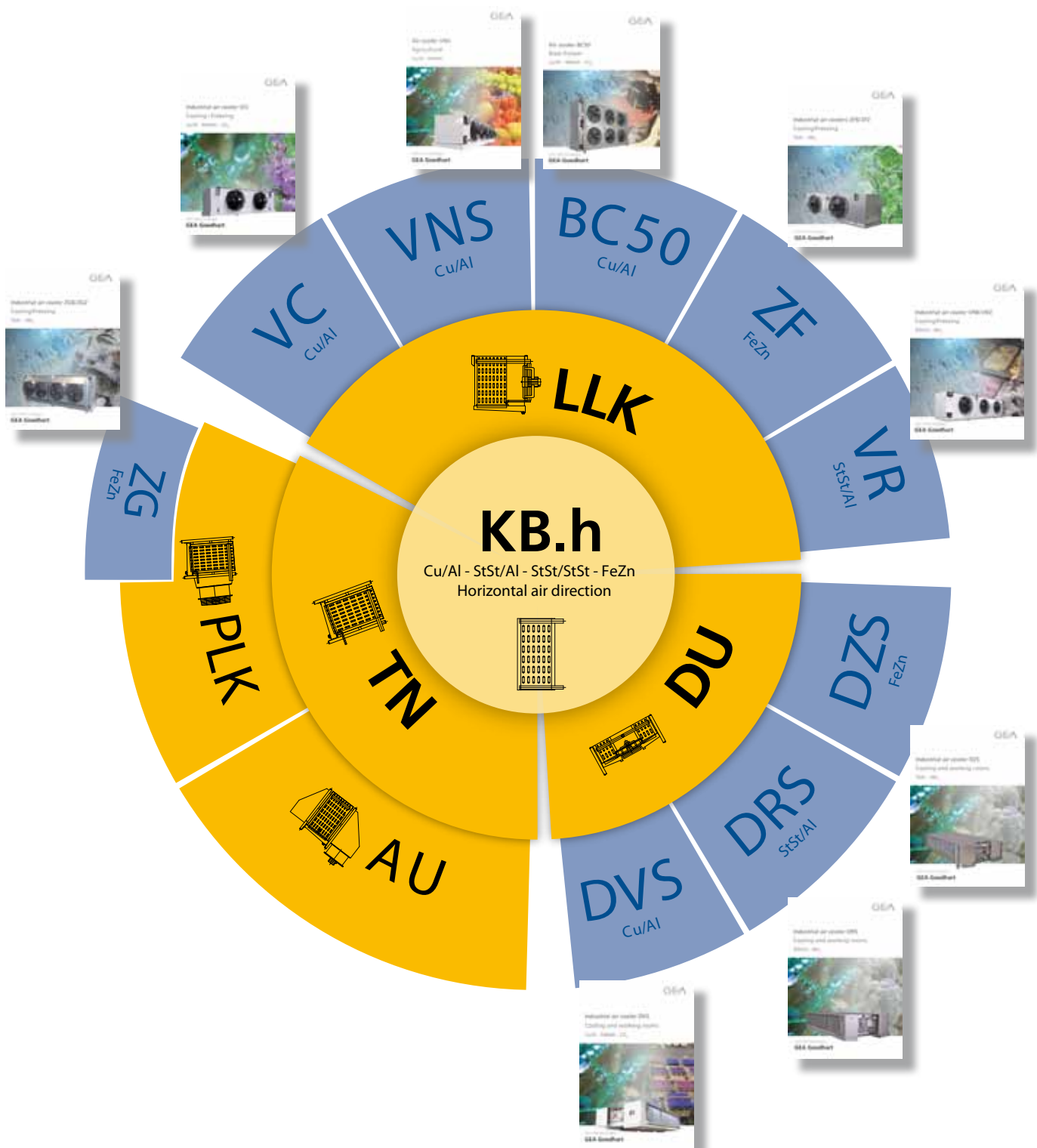



Excellence

Passion

Integrity

Responsibility

GEA-versity

GEA Group is a global mechanical engineering company with multi-billion euro sales and operations in more than 50 countries. Founded in 1881 the company is one of the largest providers of innovative equipment and process technology. GEA Group is listed in the STOXX Europe 600 Index.



## GEA Heat Exchangers

GEA Goedhart B.V.

Nijverheidsweg 6, 4695 RC Sint Maartensdijk  
The Netherlands  
Phone +31 (0)166 665 665, Fax+31 (0)166 663 698  
[www.goedhart.nl](http://www.goedhart.nl),  
[info.goedhart.nl@geagroup.com](mailto:info.goedhart.nl@geagroup.com)

## GEA Heat Exchangers

GEA Goedhart s.r.o.

Kostomlátecká 180, 288 26 Nymburk  
Czech Republic  
Phone +420 325 519 951, Fax+420 325 519 952  
[www.goedhart.cz](http://www.goedhart.cz),  
[goedhart.cz@geagroup.com](mailto:goedhart.cz@geagroup.com)